

	F1-EM	F1-M	F1-SM	F1-FM	F1-LP
Altezza Piattaforma mm.	75	75	75	75	75
Altezza bobina film mm.	500	500	500	500	500
Diametro max. bobina film mm.	300	300	300	300	300
Regolazione indipendente numero giri parte bassa/alta del pallet	■	■	■	■	■
Selettore programma Manuale/Automatiko	■	■	■	■	■
Carrello con freno meccanico tipo EM	■				
Carrello con freno meccanico tipo M		■			
Carrello con prestiro meccanico 30-60-90% tipo SM			■		
Carrello con Freno magnetico tipo FM				■	
Carrello con prestiro motorizzato 200% tipo LP					■
Velocità piattaforma regolabile tramite inverter con partenza lenta e arresto progressivo	■	■	■	■	■

	F1-EM	F1-M	F1-SM	F1-FM	F1-LP
Turntable height mm.	75	75	75	75	75
Maximum height of film mm.	500	500	500	500	500
Maximum diameter of film roll mm.	300	300	300	300	300
Number of wraps at the pallet base and top adjustable independent	■	■	■	■	■
Possibility to choose manual or automatic programs	■	■	■	■	■
Film tension control by mechanical brake type EM	■				
Film tension control by mechanical brake type M		■			
Film tension control by mechanical pre-stretch 30-60-90% type SM			■		
Film tension control by electromagnetic brake type FM				■	
Film tension control by power pre-stretch 200% type LP					■
Adjustment of turntable speed with Inverter - slow start a fix stop	■	■	■	■	■

	F1-EM	F1-M	F1-SM	F1-FM	F1-LP
Hauteur du plateau mm.	75	75	75	75	75
Hauteur maximum de la bobine de film mm.	500	500	500	500	500
Diamètre maximum de la bobine de film mm.	300	300	300	300	300
Programmation indépendant des tours sur les partie inf./sup. de la palette	■	■	■	■	■
Possibilité de choix cycle manuel / automatique	■	■	■	■	■
Chariot porte-bobine avec frein mécanique type EM	■				
Chariot porte-bobine avec frein mécanique type M		■			
Chariot porte-bobine avec pre-étirage mécanique 30-60-90% type SM			■		
Chariot porte-bobine avec frein électromagnétique type FM				■	
Chariot porte-bobine avec pre-étirage motorisé 200% type LP					■
Vitesse réglable du plateau avec inverter, démarrage progressif plus arrete in position	■	■	■	■	■

	F1-EM	F1-M	F1-SM	F1-FM	F1-LP
Drehtellerhöhe mm.	75	75	75	75	75
Folienrollenhöhe mm.	500	500	500	500	500
Max. Durchmesser der Folienrolle mm.	300	300	300	300	300
Selbständige Regulierung der oberen-unteren Wicklungen der Palette	■	■	■	■	■
Programmwähler manuell/automatisch	■	■	■	■	■
Trägerrolle mit mechanischen Bremsen type EM	■				
Trägerrolle mit mechanischen Bremsen type M		■			
Trägerrolle mit 30-60-90% mechanischer Verreckung type SM			■		
Trägerrolle mit elektromagnetischen Bremsen type FM				■	
Trägerrolle mit 200 % angetriebener Vorreckung type LP					■
Drehtellergeschwindigkeit mittels Inverter einstellbar und langsamer Start und Halt in Stellung	■	■	■	■	■

	F1-EM	F1-M	F1-SM	F1-FM	F1-LP
Altura plataforma mm.	75	75	75	75	75
Altura máxima bobina film mm.	500	500	500	500	500
Diametro max. bobina film mm.	300	300	300	300	300
Programación vueltas en base del palet y en la parte superior	■	■	■	■	■
Posibilidad de trabajo en ciclo manual o automatico	■	■	■	■	■
Carro con freno mecanico tipo EM	■				
Carro con freno mecanico tipo M		■			
Carro con prestiro mecanico 30-60-90% tipo SM			■		
Carro con freno eletromagnetico tipo FM				■	
Carro con prestiro motorizado 200% tipo LP					■
Velocidad regulable de la plataforma con inverter - Partenza lenta e arresto in posizione	■	■	■	■	■

www.zen-adv.com

Cod.pubbli.-SBC0010229

**AVVOLGIBANCALI SEMI-AUTOMATICO**  
**SEMI-AUTOMATIC STRETCH WRAPPER**  
**BANDEROLEUR SEMI-AUTOMATIQUE**  
**HALBAUTOMATISCHE PALETTENWICKELMASCHINE**  
**ENFARDADORA DE PALETS SEMI-AUTOMATICO**



# PAKLET F1-F1HS



Carrello portabobina film con:  
Film carriage with:  
Chariot porte-bobine avec:  
Trägerrolle mit:  
Carro portabobina con:

# PAKLET F1-F1HS



- EM**
- Freno meccanico diretto "Economico"
  - Mechanical brake direct "Economic"
  - Frein mécanique direct "Economic"
  - Mechanischen Bremsen gerade "Billig"
  - Freno mecanico diretto "Economico"

- M**
- Freno meccanico
  - Mechanical brake
  - Avec frein mécanique
  - Mit mechanischen Bremsen
  - Con freno mecanico

- FM**
- Freno elettromagnetico
  - Electromagnetic brake
  - Frein électromagnétique
  - Elektromagnetischen Bremsen
  - Freno electromagnetico

- SM**
- Prestiro meccanico 30-60-90%
  - Mechanical Pre-stretch 30-60-90%
  - Prè-étirage mécanique 30-60-90%
  - 30-60-90% angetriebener Vorreckung
  - Prestiro mecanico 30-60-90%

- LP**
- Prestiro motorizzato 200%
  - Powered Pre-stretch 200%
  - Prè-étirage motorisé 200%
  - 200% angetriebener Vorreckung
  - Prestiro motorizado 200%

- In versione inox
- Stainless steel version
- En version inox
- Edelstahl
- En versión inoxidable



- Fotocellula altezza pallet (standard)
- Pallet height sensing photocell
- Cellule photo-électrique pour détection hauteur palette
- Phoyzellen zum Lesen der Palettenhöhe
- Fotocelula para la lectura automática de la altura del palet

- Rampa di carico 90°-180°-270°
- Loading ramp
- Rampe de chargement
- Einstellbare Laderampe
- Rampa de carga

- Colonna reclinabile incernierata alla base
- Reclinable column hinged to the base
- Colonne reclinable fixée à la base
- Umklappbare Säule am Basis befestigt
- Column reclinable sobre la base



- Pannello di controllo con freno meccanico
- Control panel with mechanical brake
- Panneau commandes avec frein mécanique
- Schaltschrank mit mechanischen Bremsen
- Panel de control con freno mecanico

- Pannello di controllo con freno magnetico/prestiro motorizzato.
- Control panel with electromagnetic brake/pre-stretch
- Panneau commandes avec frein electromagnétique/prè-étirage
- Schaltschrank mit elektromagnetischen Bremsen/antriebener Vorreckung.
- Panel de control con freno electromagnetico/prestiro

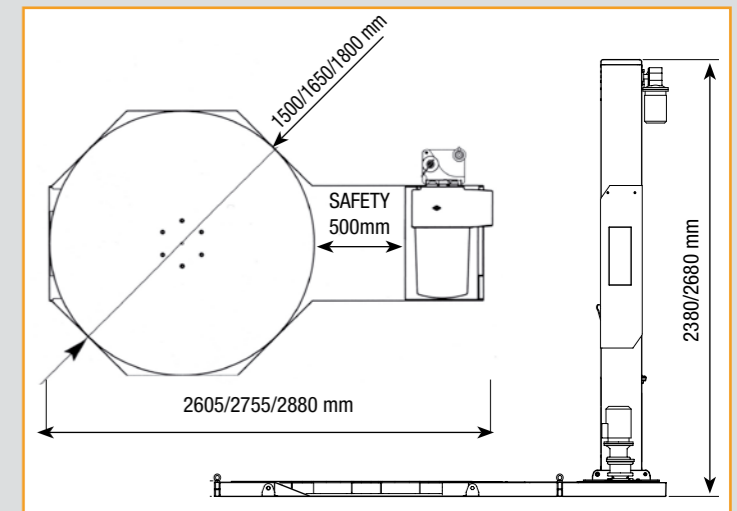

- Inforcabilità anteriore e posteriore per facilitarne lo spostamento
- Possibility to pitchfork the machine anteriorly and posteriorly
- Possibilité de déplacer la machine par un elevateur
- Vordere und hintere Möglichkeit, die Maschine zu bewegen
- Con enganche delantero y posterior para facilitar el desplazamiento

**SIAT**  
M. J. MAILLIS GROUP



PAKLET F1	L	W	H	Kg max
Ø 1500	1200	800	2100/2400	2000
Ø 1650	1200	1000	2100/2400	2000
Ø 1800	1200	1200	2100/2400	2000
PAKLET F1-HS	L	W	H	Kg max
Ø 1500	1200	800	2100/2400	1200

- Diametro piattaforma 1500/1650/1800 mm max. 2000 Kg
- Tunttable diamete 1500/1650/1800 mm 2000 Kg max.
- Diamètre du plateau 1500/1650/1800 mm max. 2000 Kg
- Drehtellerdurchmesser 1500/1650/1800 mm 2000 Kg max.
- Diametro plataforma 1500/1650/1800 mm max. 2000 Kg

- Modello/Model/Type/Typ/Tipo F1-HS**
- Diametro piattaforma 1500mm max. 1200 Kg
  - Tunttable diamete 1500mm 1200 Kg max.
  - Diamètre du plateau 1500mm max. 1200 Kg
  - Drehtellerdurchmesser 1500mm 1200 Kg max.
  - Diametro plataforma 1500mm max. 1200 Kg

